

APPARATUS AND DEMONSTRATION NOTES

The downloaded PDF for any Note in this section contains all the Notes in this section.

Frank L. H. Wolfs, *Editor*

Department of Physics and Astronomy, University of Rochester, Rochester, New York 14627

This department welcomes brief communications reporting new demonstrations, laboratory equipment, techniques, or materials of interest to teachers of physics. Notes on new applications of older apparatus, measurements supplementing data supplied by manufacturers, information which, while not new, is not generally known, procurement information, and news about apparatus under development may be suitable for publication in this section. Neither the *American Journal of Physics* nor the Editors assume responsibility for the correctness of the information presented.

Manuscripts should be submitted using the web-based system that can be accessed via the *American Journal of Physics* home page, <http://ajp.dickinson.edu> and will be forwarded to the ADN editor for consideration.

Gamma ray spectroscopy with a silicon photomultiplier and a LYSO crystal

Abaz Kryemadhi^{a)} and Kyler Chrestay

Department of Information and Mathematical Sciences, Messiah College, Mechanicsburg, Pennsylvania 17055

(Received 20 February 2014; accepted 27 October 2014)

Gamma ray spectroscopy has traditionally been expensive for undergraduate physics laboratories due to needs of a multichannel analyzer, gamma-ray detector, and associated electronic modules. We have designed a low-cost, gamma-ray spectroscopy apparatus for physics labs using a silicon photomultiplier as a photodetector, a Cerium Lutetium-Yttrium OxyorthoSilicate crystal for scintillation, and a digital oscilloscope driven by LabVIEW. The setup could be used either alongside traditional gamma-ray detectors or as a standalone for educating students with techniques used in nuclear and particle physics. © 2015 American Association of Physics Teachers.

[<http://dx.doi.org/10.1119/1.4901236>]

I. INTRODUCTION

Gamma ray spectroscopy is commonly incorporated in the physics curriculum as part of a modern physics or advanced laboratory course, with Cs-137, Am-241, Co-57, and Na-22 typically used as the gamma-emitters. These isotopes are in excited states, and gamma rays with characteristic energy spectra are emitted when they return to the ground state. The spectral features produced by gamma-ray interaction with the scintillator are well described.^{1,2}

A traditional gamma-ray detector consists of a Sodium Iodide crystal activated with small amounts of Thallium, known as NaI(Tl) detectors, with the Tl dopant used to convert incoming gamma energy losses in the scintillator to optical photons. A photomultiplier tube (PMT) then converts optical photons into electrical-current pulses, and a multichannel analyzer (MCA) processes and sorts the pulses by amplitude (or height).¹⁻⁴ While the traditional technique has been robust and used in many areas of research, the cost of MCAs, as standalone or in a nuclear instrumentation module (NIM) crate, can limit its implementation at small undergraduate institutions. Additionally, the MCAs do all the analysis internally, making it difficult for students to fully understand the signal processing. Some attempts have been made to incorporate lower-cost gamma spectroscopy in education, but they have been limited by the technology of the time,^{4,5} or the more recent ones have not been intuitive enough for student learning.⁶

Our goals in this work are to reduce the cost of gamma ray spectroscopy in education by using equipment already available in a physics lab, while introducing new photodetectors and crystals currently used in nuclear and particle physics. We show in this paper that we have achieved these goals using an oscilloscope with LabVIEW for data logging, a silicon photomultiplier (SiPM) as a new photodetector, and a small inexpensive Cerium Lutetium-Yttrium OxyorthoSilicate (LYSO) crystal for scintillation.

II. EXPERIMENT

Our detector consists of a SiPM and a LYSO crystal. A SiPM is an array of avalanche photo diodes (APDs) connected in parallel where individual APDs are connected in series with a quenching resistor, as shown in Fig. 1(a).⁷ The APD becomes sensitive to low light levels by operating with a reverse voltage above its breakdown voltage. The signals from each APD are summed into a signal at the output of the SiPM, which is proportional to the number of photoelectrons. The SiPM readout circuit is shown in Fig. 1(b), where the 10 k Ω resistor limits current to the device, and the 0.1- μ F capacitor minimizes stray noise from the ground. The SiPM in our experiment is produced by STMicroelectronics Company of Catania, Italy and it is 3 mm \times 3 mm in size.⁸ The SiPM was operated at 30 V (1 V above the breakdown voltage) as per manufacturer's recommendations.

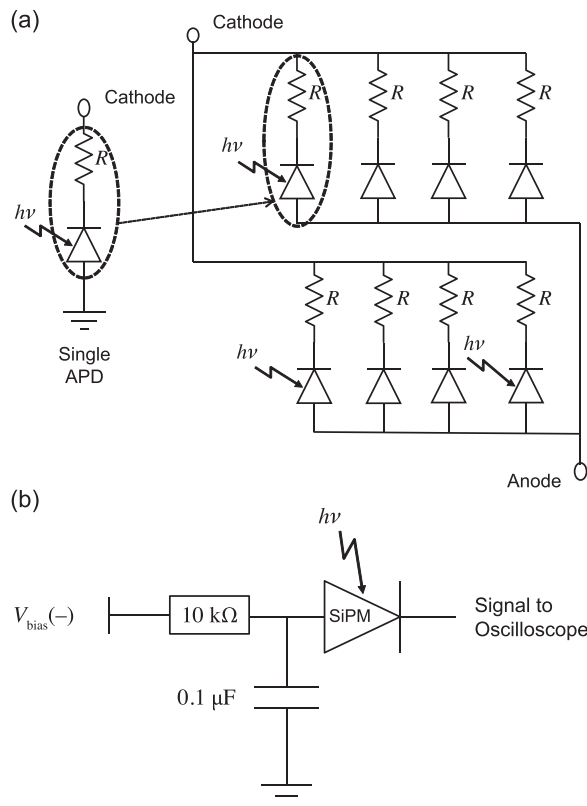

Fig. 1. (a) Arrangement of individual APDs inside a SiPM (Ref. 7). (b) The circuit diagram for SiPM.

The LYSO crystals are currently being used in particle physics and positron emission tomography due to their high photon yield and small decay time.^{9,10} A LYSO crystal has a light yield of ≈ 25000 photons/MeV, a time decay constant of ≈ 40 ns, and a peak emission wavelength of 420 nm. The SiPM particle detection efficiency at this wavelength is $\approx 20\%$. We used a $10\text{ mm} \times 3\text{ mm} \times 3\text{ mm}$ LYSO crystal obtained from Proteus Inc.¹¹ The crystal was wrapped with Teflon tape to increase the photon yield into the SiPM by reflecting the photons back into the crystal.

The experimental setup is shown in Fig. 2(a). A power supply provides the bias voltage to the SiPM, and the LYSO crystal sits on top of the SiPM. The signals from the SiPM are then sent to the oscilloscope using a $50\ \Omega$ load terminator. Figure 2(b) shows a sample signal. The gamma-ray source set was obtained from Spectrum Techniques.¹²

The oscilloscope is connected to a computer via USB cable. We used Tektronix oscilloscope TDS2024B, but any digital oscilloscope capable of data logging with a bandwidth of greater than 40 MHz and sample rate of greater than 200 MSa/s will work. The vertical resolution of the oscilloscope is 8 bit, which yields $2^8 = 256$ possible channels or bins. Because of digitization from analog-to-digital (ADC) inside the oscilloscope, there will be a discrete set of possible voltage amplitudes and gamma ray energies. For example, by setting Volts/div = 500 mV, there are ten vertical divisions on this oscilloscope, making the ADC resolution ($10 \times 500\text{ mV}/256$) = 19.5 mV. The trigger threshold reduces random background events and keeps the event rate manageable, and is set differently for different isotopes. The oscilloscope collects events at a trigger rate of 2 Hz. This small event rate is limited by the oscilloscope, not the detector

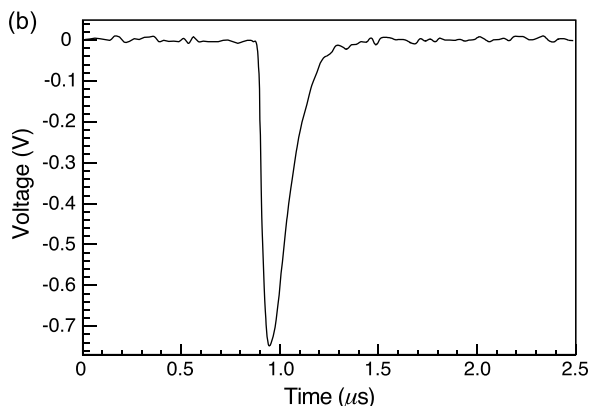
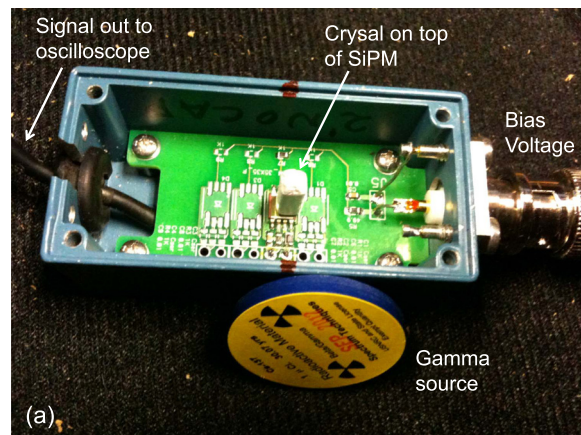

Fig. 2. (a) Setup of the experiment with LYSO crystal on top of SiPM. (b) Sample input signal on the oscilloscope showing Voltage (500 mV for vertical division) versus time (250 ns per horizontal division); the amplitude of this signal is proportional to incoming gamma ray energy.

efficiency. Once the data are collected, the spectra have to be calibrated to match the channel number with a known energy. We used the Cs-137 peak at 662 keV for calibration and found the calibration constant to be 15 keV/channel. We maintained the same overvoltage for the rest of the samples and applied this calibration constant to the rest to convert from channel number to energy.

LABVIEW Signal Express software was used for automatic data logging of events.¹³ It has a very user friendly graphical user interface to select the desired quantities for logging with minimal coding. For every event, we recorded the peak height of signals such as the one shown in Fig. 2(b).

III. RESULTS

Figure 3 shows the spectra for Cs-137, Ba-133, Na-22, and Co-57 using a peak finding macro in the free ROOT analysis package.¹⁴ The spectra do not extend all the way to zero due to the trigger threshold cut. The photopeaks are at 656 keV for Cs-137, 529 keV for Na-22, 88 keV and 298 keV for Ba-133, and 120 keV for Co-57. The full width at half maximum (FWHM) is $\text{FWHM} = 2.35\sigma$ for a Gaussian distribution, where σ is the standard deviation.² The measured resolution comprised the intrinsic resolution of the crystal, which is affected by defects in the crystal and the non-linear response of the crystal to different energies, and the statistical resolution, which is given by $2.36 \times 100/\sqrt{N_{\text{pe}}}$, with N_{pe} being the number of photoelectrons.^{2,15} The peaks, resolutions, and Compton edges are summarized in Table I for

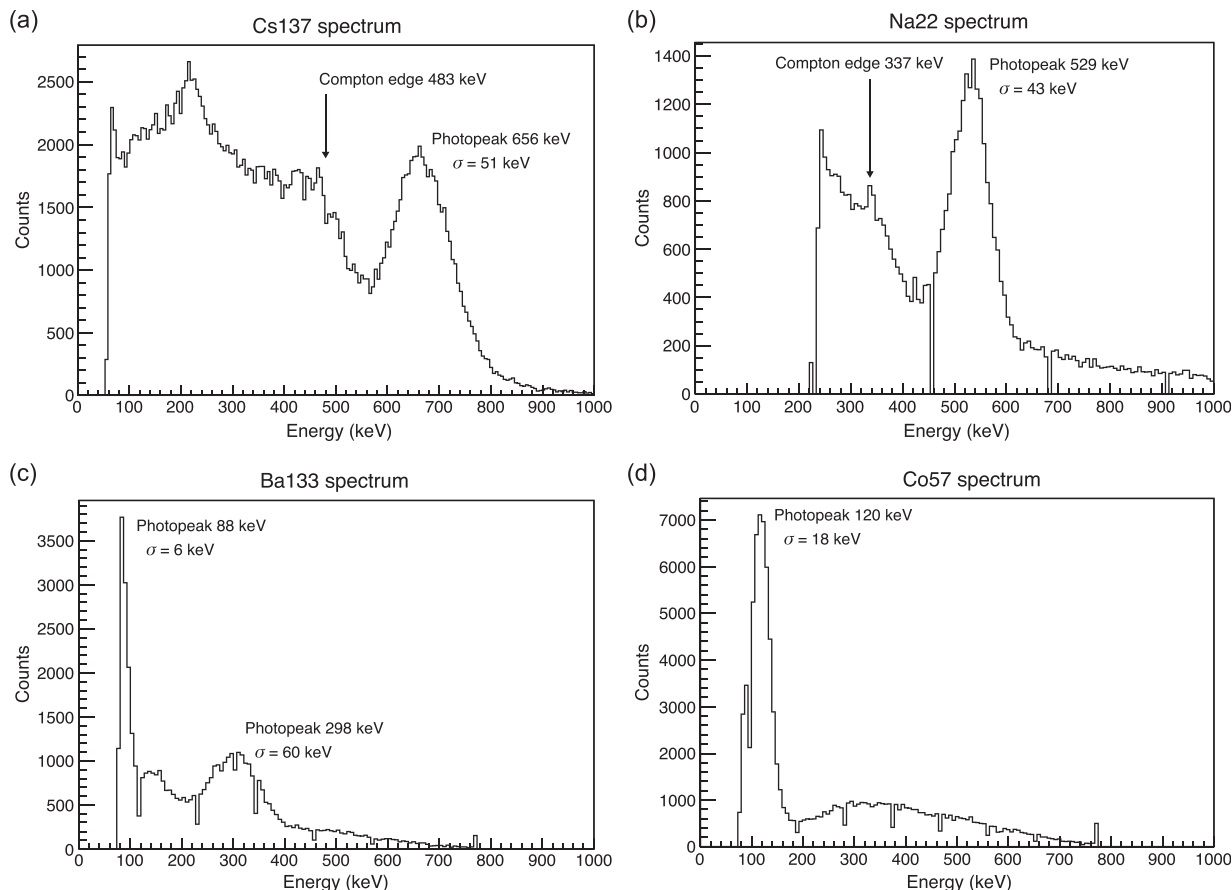

Fig. 3. Energy spectra of four common isotopes.

these isotopes. Resolution improvements could be achieved by putting silicon grease between the crystal and SiPM and wrapping the crystal with a high reflectivity diffuse material. The predicted Compton edge for Cs-137 is at 477 keV, and the measured edge is at 483 keV. For Na-22 the predicted edge is at 340 keV, and the measured Compton edge is at 337 keV. The wide resolution smears out Compton features for Ba-133 and Co-57.

From an educational perspective, the method provides an excellent exposure to the Compton Effect, interaction of gamma rays with matter, electrical and optical properties of modern detectors, the detector response and detector resolution, and analog-to-digital converters. While the educational benefits of the method are tremendous, the wider resolution of LYSO compared to NaI(Tl) limits the number of features one can see and the small event rate with the oscilloscope limits the acquisition time. We therefore recommend its use alongside a NaI(Tl) crystal if available, which is instructive in and of itself. We also recommend the use of Cs-137 or Na-22 to study the Compton Effect if done as part of the modern physics class, and study of the other isotopes if part of an advanced laboratory or a senior project.

Table I. Summary of the results.

Isotope	Predicted peak (keV)	Measured peak (keV)	Resolution (FWHM/E*100)	Predicted Compton edge (keV)	Measured Compton edge (keV)
Ba-133	81,303	88,298	17%, 47%
Cs-137	662	656	19%	477	483
Na-22	511	529	19%	340	337
Co-57	122	120	35%

IV. COSTS

The cost of the experiment is summarized in Table II. We used a SiPM from STMicroelectronics but the company makes limited supplies of them. One can acquire, however, a SiPM from Advansid conveniently and cost effectively.¹⁶ Their 3 mm SiPM is \$50 and their evaluation board ASD-EP-EB-PZ plus a 3 mm SiPM is about \$200. The cost of the crystal for the size mentioned is about \$100. For a “light-tight” operating environment, we converted a file folder (\$40) to a dark box. The detector cost ranges from \$190 to \$340, assuming a digital oscilloscope (\approx \$1000) and LabVIEW (\approx \$1500 per year for 20 licenses) are already in the physics lab.

V. CONCLUSION

The main spectral components of Cs-137, Na-22, Ba-133, and Co-57 have been clearly identified using a SiPM as a novel photodetector, LabVIEW for data logging, and a small LYSO crystal in a cost-effective manner. While there are some limitations to the technique, such as a slow event rate and wider resolution of LYSO versus NaI(Tl) crystals, the

Table II. Summary of costs.

Item	Description	Cost
SiPM	3 mm × 3 mm AdvansId SiPM (without) with evaluation board	(\$50) \$200
LYSO	Proteus Inc. 10 mm × 3 mm × 3 mm crystal	\$100
Dark Box	Vaultz black	\$40
Total	Cost range	\$190–\$340

educational benefits for students in exposing them to nuclear and particle physics techniques are enormous. Assuming an oscilloscope, LabVIEW, and the isotopes are available, the cost of the detector setup is in the range of \$190–\$340. We recommend using this setup as a Compton Effect study in a modern physics lab with just Cs-137 or Na-22, or to do a full gamma-ray spectroscopy experiment for a senior project or advanced laboratory. If a NaI(Tl) detector is already available, it would be instructive to compare the crystal performances. If LabVIEW is not available, the experiment can still be educationally useful with just the oscilloscope because it gives students background in electrical and optical properties of modern detectors.

ACKNOWLEDGMENTS

The authors thank the Fermilab Cryogenic Dark Matter Search (CDMS) experiment, where the project was initially conceived out of our work towards studying SiPMs for a possible neutron veto detector to be used in Super CDMS, Anatoly Ronzhin and Sergei Los (Fermilab) for providing the SiPM, engineering student Joel Love for providing help with LabVIEW, and Messiah College for support of the project.

^a)Electronic mail: akryemadhi@messiah.edu; Permanent address: One College Avenue, Messiah College, Department of Information and Mathematical Sciences, Suite 3041 Mechanicsburg, Pennsylvania 17055.

¹A. C. Melissinos and J. Napolitano, *Experiments in Modern Physics*, 2nd ed. (Academic Press, Waltham, Massachusetts, 2003).

²G. Knoll, *Radiation Detection and Measurements*, 4th ed. (Wiley, Hoboken, New Jersey, 2010).

³For a variety of experiments in nuclear physics, among them Gamma-Ray Spectroscopy see “Using NaI(Tl),” at <<http://www.ortec-online.com/solutions/educational.aspx>>.

⁴R. H. Chow and J. S. Herald, “Compton-scattering experiment using low-activity gamma-ray sources,” *Am. J. Phys.* **33**, 1042–1047 (1965).

⁵M. J. Wozniak, Jr., “Turn your apple microcomputer into an economical pulse height analyzer for gamma-ray spectroscopy,” *Am. J. Phys.* **49**, 700–701 (1981).

⁶D. Prutchi and S. R. Prutchi, *Exploring Quantum Physics Through Hands on Projects* (J. Wiley and Sons, Hoboken, New Jersey, 2012), Gamma Ray Spectroscopy using sound card, <<http://www.theremino.com/blog/gamma-spectrometry>>, for a system that uses a sound card, <<http://www.gammaspectacular.com/gamma-spectroscopy>>.

⁷See the SensL library <<http://www.sensl.com/documentation>> for an overview of Silicon photomultipliers. For a detailed simulation of electrical properties, see S. Seifert, H. T. van Dam, J. Huizenga, R. Vinke, P. Dendooven, and H. Lohner, “Simulation of silicon photomultiplier signals,” *IEEE Trans. Nucl. Sci.* **56**(6), 3726–3734 (2009).

⁸For the SiPM used in our experiment, see <http://www.st.com/web/en/about_st/careers/catania.html>.

⁹J. Chen *et al.*, “Large size LSO and LYSO crystals for future high energy physics experiments,” *IEEE Trans. Nucl. Sci.* **54**(3), 718–724 (2007).

¹⁰R. Slates, S. Cherry, A. Boutefnouchet, Y. Shao, M. Dahlborn, and K. Farahani, “Design of a small animal MR compatible PET scanner,” *IEEE Trans. Nucl. Sci.* **46**(3), 565–570 (1999).

¹¹C. M. Pepin *et al.*, “Properties of LYSO and recent LSO scintillators for Phoswich PET detectors,” *IEEE Trans. Nucl. Sci.* **51**(3), 789–796 (2004).

¹²For information where to get the gamma ray sources see <<http://www.spectrumtechniques.com>>.

¹³More information about LabVIEW signal express can be found at <<http://www.ni.com/labview/signalexpress>>.

¹⁴Open source software used in particle physics is available at <<http://www.root.cern.ch>>.

¹⁵D. R. Curry and P. B. Siegel, “Data analysis in the undergraduate nuclear laboratory,” *Am. J. Phys.* **63**, 71–76 (1995).

¹⁶Advanced silicon detectors can be found online at <<http://www.advansid.com>>.